

# TB 9-4910-555-35

CHANGE 1

DEPARTMENT OF THE ARMY TECHNICAL BULLETIN

---

## CALIBRATION PROCEDURE FOR SIMPLIFIED TEST EQUIPMENT FOR INTERNAL COMBUSTION ENGINE (STE/ICE-R)

---

Headquarters, Department of the Army, Washington, DC  
21 April 2004

---

*Distribution Statement A: Approved for public release; distribution is unlimited.*

---

TB 9-4910-555-35, 24 July 2003, is changed as follows:

1. Remove old pages and insert new pages as indicated below. New or changed material is indicated by a vertical bar in the margin of the page.

**Remove Pages**

11 and 12  
13 and 14

**Insert Pages**

11 and 12  
13 and 14

2. File this change sheet in front of the publication for reference purposes.

**By Order of the Secretary of the Army:**

Official:

  
JOEL B. HUDSON

*Administrative Assistant to the  
Secretary of the Army*

**PETER J. SCHOOMAKER**  
*General, United States Army  
Chief of Staff*

0405602

Distribution:

To be distributed in accordance with IDN 342040, requirements for TB 9-4910-555-35.



# \*TB 9-4910-555-35

DEPARTMENT OF THE ARMY TECHNICAL BULLETIN

## CALIBRATION PROCEDURE FOR SIMPLIFIED TEST EQUIPMENT FOR INTERNAL COMBUSTION ENGINE (STE/ICE-R)

Headquarters, Department of the Army, Washington, D. C.  
24 July 2003

*Approved for public release; distribution is unlimited.*

### REPORTING OF ERRORS AND RECOMMENDING IMPROVEMENTS

You can improve this manual. If you find any mistakes or if you know of a way to improve these procedures, please let us know. Mail your letter or DA Form 2028 (Recommended Changes to Publications and Blank Forms) directly to: Commander, U.S. Army Aviation and Missile Command, ATTN: AMSAM-MMC-MA-NP, Redstone Arsenal, AL 35898-5000. A reply will be furnished to you. You may also provide DA Form 2028 information to AMCOM via e-mail, fax, or the World Wide Web. Our fax number is DSN 788-6546 or Commercial 256-842-6546. Our e-mail address is: [2028@redstone.army.mil](mailto:2028@redstone.army.mil). Instructions for sending an electronic 2028 may be found at the back of this manual. For the World Wide Web, use <https://amcom2028.redstone.army.mil>.

SECTION		Paragraph	Page
	I. IDENTIFICATION AND DESCRIPTION		
	Test instrument identification .....	1	2
	Forms, records, and reports.....	2	2
	Calibration description .....	3	2
	II. EQUIPMENT REQUIREMENTS		
	Equipment required.....	4	3
	Accessories required.....	5	3
	III. CALIBRATION PROCESS FOR VEHICLE TEST METER (VTM)		
	Preliminary instructions.....	6	4
	Equipment setup .....	7	4
	Dc voltage .....	8	5
	Resistance .....	9	7
	Dc current .....	10	8
	Frequency .....	11	10
	RPM .....	12	11
	Pressure .....	13	12
	Vacuum .....	14	14
	Final procedure .....	15	14

\*This technical bulletin supersedes TB 9-4910-555-35, dated 6 January 1997, including all changes.

**SECTION I  
IDENTIFICATION AND DESCRIPTION**

**1. Test Instrument Identification.** This bulletin provides instructions for the calibration of Simplified Test Equipment for Internal Combustion Engine (STE/ICE-R). TM 9-4910-571-12&P and TM 9-4910-571-34&P were used as the prime data sources in compiling these instructions. The equipment being calibrated will be referred to as the TI (test instrument) throughout this bulletin.

**a. Model Variations.** The STE/ICE-R is reprogrammable.

**b. Time and Technique.** The time required for this calibration is approximately 4 hours, using the dc/low physical techniques.

**2. Forms, Records, and Reports**

**a.** Forms, records, and reports required for calibration personnel at all levels are prescribed by TB 750-25.

**b.** Adjustments to be reported are designated (R) at the end of the sentence in which they appear. When adjustments are in tables, the (R) follows the designated adjustment. Report only those adjustments made and designated with (R).

**3. Calibration Description.** TI parameters and performance specifications which pertain to this calibration are listed in table 1.

Table 1. Calibration Description

Test instrument parameters	Performance specifications
Dc voltage <sup>1</sup>	Range: 0 to .49 V dc Accuracy: $\pm 6\%$ of FS Range: .50 to 4.49 V dc Accuracy: $\pm 3\%$ of FS Range: 4.50 to 45 V dc Accuracy: $\pm 1\%$ of FS
Dc current <sup>1</sup>	Range: 0 to 1500 A Accuracy: $(+7.0 \text{ to } 8.0\% \text{ of input}) + (\pm 2\% \text{ of FS})^2$
Resistance <sup>1</sup>	Range: $0\Omega$ to $4500\Omega$ Accuracy: $(\pm 3.0\% \text{ of indication}) + (\pm 0.2\% \text{ of FS})$ Range: $0\Omega$ to $40,000\Omega$ Accuracy: $(\pm 3\% \text{ of indication}) + (\pm 0.5\% \text{ of FS})$
Frequency	Range: 40 to 500 Hz Accuracy: $(\pm 7\% \text{ of input}) + (\pm 0.65\% \text{ of FS})$
RPM	Range: 50 to 5000 RPM Accuracy: $\pm 0.5\%$ of FS

See notes at end of table

Table 1. Calibration Description - Continued

Test instrument parameters	Performance specifications
Pressure <sup>1</sup>	Range: 0 to 25 psig 0 to 1000 psig Accuracy: ( $\pm 2.5\%$ of indication) + ( $\pm 1.5\%$ of FS)
Vacuum	Range: 0 to 30 inHg Accuracy: ( $\pm 2.5\%$ of indication) + ( $\pm 1.5\%$ of FS)

<sup>1</sup>Offset test required

<sup>2</sup>Max error is 7.0% up to 1000 amperes and increases linearity to 8.0% at 1500 amperes

## SECTION II EQUIPMENT REQUIREMENTS

**4. Equipment Required.** Table 2 identifies the specific equipment to be used in this calibration procedure. This equipment is issued with Secondary Transfer Calibration Standards Set AN/GSM-286, AN/GSM-287, or AN/GSM-705. Alternate items may be used by the calibrating activity. The items selected must be verified to perform satisfactorily prior to use and must bear evidence of current calibration. The equipment must meet or exceed the minimum use specifications listed in table 2. The accuracies listed in table 2 provide a four-to-one ratio between the standard and TI.

**5. Accessories Required.** The accessories listed in table 3 are issued as indicated in paragraph 4 above and are used in this calibration procedure. When necessary, these items may be substituted by equivalent items, unless specifically prohibited.

Table 2. Minimum Specifications of Equipment Required

Common name	Minimum use specifications	Manufacturer and model (part number)
CALIBRATOR	Range: 0 to 45 V dc Accuracy: $\pm 0.25\%$	John Fluke, Model 5720A(p/o MIS-35947); w/power amplifier, John Fluke Model 5725A (5725A)
DC CURRENT SHUNT	Range: 0 to 75 A Accuracy: <sup>1</sup>	Guildline, Model 9711 (7912323)
FUNCTION/ARBITRARY GENERATOR	Range: 0 to 10 V p-p; 500 Hz square wave Accuracy: $\pm 0.5\%$	Agilent, Model 33250A (33250A)
HYDRAULIC PRESSURE STANDARD	Range: 25 to 1000 psig Accuracy: $\pm 1\%$	DHI, RPM3D-A10000 (13534030)
MULTIMETER	Range: 0 to 75 mV dc Accuracy: <sup>1</sup>	Hewlett-Packard, Model 3458A (3458A)
PNEUMATIC PRESSURE STANDARD	Range: 0 to 25 psig; 0 to 1000 psig Accuracy: $\pm 1\%$	Druck, Model DPI-145/R (MIS-45842)
RESISTANCE STANDARD	Range: $0\Omega$ to $40,000\Omega$ Accuracy: $0\Omega$ to $1500\Omega$ $+0.9\%$ $1500\Omega$ to $40,000\Omega$ $+0.85\%$	Biddle-Gray, Model 71-631 (7910328)

<sup>1</sup>Combined accuracy of dc current shunt and multimeter:  $\pm 1.8\%$  to  $\pm 2.1\%$ .

Table 3. Accessories Required

Common name	Description (part number)
DC POWER SUPPLY NO. 1	NJE, Model CS36CR30D2 (7907346-2)
DC POWER SUPPLY NO. 2	Dynamic Industries, Corp., Model 55314-104054 (MIS-38956)
NITROGEN SOURCE	Compressed cylinder (7916197)
PRESSURE CONTROLLER	(MIS-10324)
PRESSURE REGULATOR	(MIS-10325, Type 2)
VACUUM PUMP	(7915882)

### SECTION III

#### CALIBRATION PROCESS FOR VEHICLE TEST METER (VTM)

##### 6. Preliminary Instructions

a. The instructions outlined in paragraphs 6 and 7 are preparatory to the calibration process. Personnel should become familiar with the entire bulletin before beginning the calibration.

b. Items of equipment used in this procedure are referenced within the text by common name as listed in tables 2 and 3.

c. Unless otherwise specified, verify the result of each test and, whenever the test requirement is not met, take corrective action before continuing with the calibration. Adjustments required to calibrate the TI are included in this procedure. Additional maintenance information is contained in TM 9-4910-571-12&P and TM 9-4910-571-34&P for this TI.

d. Unless otherwise specified, all controls and control settings in this section refer to the TI. **Label current probe, high-pressure transducer , and low-pressure transducer with the following: “To be used only with VTM, Serial # \_\_\_\_\_ for VTM calibration to be valid”.**

##### 7. Equipment Setup

#### WARNING

HIGH VOLTAGE is used or exposed during the performance of this calibration. DEATH ON CONTACT may result if personnel fail to observe safety precautions. REDUCE OUTPUT(s) to minimum after each step within the performance check where applicable.

a. Connect cable W2 to TI J4 connector.

b. Connect cable W5 to TI J1 connector.

c. Connect cable W5 red and black leads to the + (positive) and - (negative) terminals of dc power supply No. 1. Observe polarity.

**NOTE**

Dc power supply No. 1 will remain connected, as stated in c above, throughout this procedure unless otherwise specified.

**CAUTION**

Throughout this procedure be sure dc power supply No. 1 is adjusted for 24 V dc output before pressing the TI power switch to **ON** position.

d. Adjust dc power supply No. 1 for 24 V dc output.

e. Press power switch to **ON** position. Verify that TI displays **8.8.8.8.** two times and then automatically starts self-test. After several numbers appear (approximately 15 seconds), display will alternate between the software revision number and the status message **PASS**. If not, perform steps f through h below.

f. Pull power switch to **OFF** position then press power switch to **ON** position. Verify that TI displays **8.8.8.8.** for about 2 seconds then becomes — — — —.

g. Set **TEST SELECT** switches to **66** and press and release **TEST** pushbutton. VTM will display **0066**.

h. Set **TEST SELECT** switches to **99** and press and release **TEST** pushbutton. After several numbers appear (approximately 15 seconds), TI will display, alternately, **PASS** and 4-digit software revision code.

## 8. Dc Voltage

### a. Performance Check

**NOTE**

If TI is turned off for any reason, repeat paragraph 7e above.

(1) Short red and black leads of cable W2 together.

(2) Set **TEST SELECT** switches to **89**.

(3) Press and hold **TEST** pushbutton until **CAL** appears on TI. Release **TEST** pushbutton.

(4) Wait for offset value to appear on display. Offset value will be between **-6.8** and **+6.8**. Press and release **TEST** pushbutton.

(5) Connect cable W2 red and black leads (shorted together) to positive connector of dc power supply No. 1. If TI does not display between -0.20 and +0.20, perform b(1) through (9) below.

**NOTE**

If adjustments are made in (5) above, leave assembly A4 on extender board for (6) through (8) below.

(6) Connect cable W2 red and black leads to calibrator + (positive) and - (negative) output connections.

(7) Press and release **TEST** pushbutton.

(8) Adjust calibrator to 40.0 V. If TI does not indicate between 39.6 and 40.4 V, perform **b**(1) through (8) below if not performed in (5) above, and **b**(10) through (12) below

**b. Adjustments**

(1) Disconnect cable W2 from + (positive) connector.

(2) Pull power switch to **OFF** position and disconnect leads from dc power supply No. 1.

(3) Remove protective cover of TI and remove assembly A4, using board removal tool (board holding bracket becomes removal tool).

**NOTE**

If extender board 2386761-501 is not available and TI requires adjustment during calibration, remove TI board, adjust "slightly," reinstall, check, and if necessary repeat technique until desired indication is obtained.

(4) Insert extender board into assembly A4 connector and insert assembly A4 into extender board.

(5) Connect W5 leads to dc power supply No. 1 and press power switch to **ON** position.

(6) Reconnect cable W2 red and black leads (shorted together) to + (positive) connector of dc power supply No. 1.

(7) Set **TEST SELECT** switches to 89. Press and hold **TEST** pushbutton until **CAL** is displayed. Release **TEST** pushbutton. Wait for offset value to appear on display.

(8) Press and release **TEST** pushbutton.



- (9) Adjust R10 on assembly A4 for display of **00.0** on TI (R).
- (10) Connect cable W2 red and black leads to calibrator + (positive) and – (negative) output connections.
- (11) Adjust calibrator to 40.0 dc V.
- (12) Adjust R3 on assembly A4 for display of **40.0** on TI (R).

## **9. Resistance**

### **a. Performance Check**

- (1) Short cable W2 red and black leads together.
- (2) Set **TEST SELECT** switches to **91**.
- (3) Press and hold **TEST** pushbutton until **CAL** appears on TI. Release **TEST** pushbutton.
- (4) Wait for offset value to appear on display. Offset value will be between **-225** and **+225**.
- (5) Connect cable W2 red and black leads to resistance standard high and low connectors. Press and release **TEST** pushbutton. Display will flash.
- (6) Adjust resistance standard controls to 1400 $\Omega$ . If TI does not indicate between 1349.0 $\Omega$  and 1451.0 $\Omega$ , perform **b(1)** through (10) below.
- (7) Set **TEST SELECT** switches to **92**.
- (8) Short cable W2 red and black leads together.
- (9) Press and hold **TEST** pushbutton until **CAL** appears on TI. Release **TEST** pushbutton.
- (10) Wait for offset value to appear on display. Offset value will be between -6.00 and +6.00.
- (11) Connect cable W2 red and black leads to resistance standard high and low connectors. Press and release **TEST** pushbutton. Display will flash.
- (12) Adjust resistance standard controls for 18,000 $\Omega$ . If TI does not indicate between 17.26 and 18.74, perform **b(1)** through (5) below (if not performed in (7) above) and **b(11)** through (13) below.

**b. Adjustments**

- (1) Set power switch to **OFF** position.
- (2) Open rear panel of TI and remove assembly A3, using board removal tool.
- (3) Insert extender board 2386761-501 into assembly A3 connector and insert A3 into extender board.
- (4) Press power switch to **ON** position.
- (5) Adjust resistance standard controls for 0.0Ω.
- (6) Set **TEST SELECT** switches to **91**.
- (7) Press and hold **TEST** pushbutton until **CAL** appears on TI. Release **TEST** pushbutton.
- (8) Wait for offset value to appear on display. Press and release **TEST** pushbutton.
- (9) Adjust resistance standard controls for 1400Ω.
- (10) Adjust R25 on assembly A3 for display of **1400** on TI (R).
- (11) Set **TEST SELECT** switches to **92**. Press and hold **TEST** pushbutton until **CAL** appears on TI. Release **TEST** pushbutton. Wait for offset value to appear on display. Press and release **TEST** pushbutton.
- (12) Adjust resistance standard controls for 18,000Ω.
- (13) Adjust R28 on assembly A3 for display of 18.00 on TI (R).

**10. Dc Current**

**a. Performance Check**

- (1) Connect equipment as shown in figure 1.

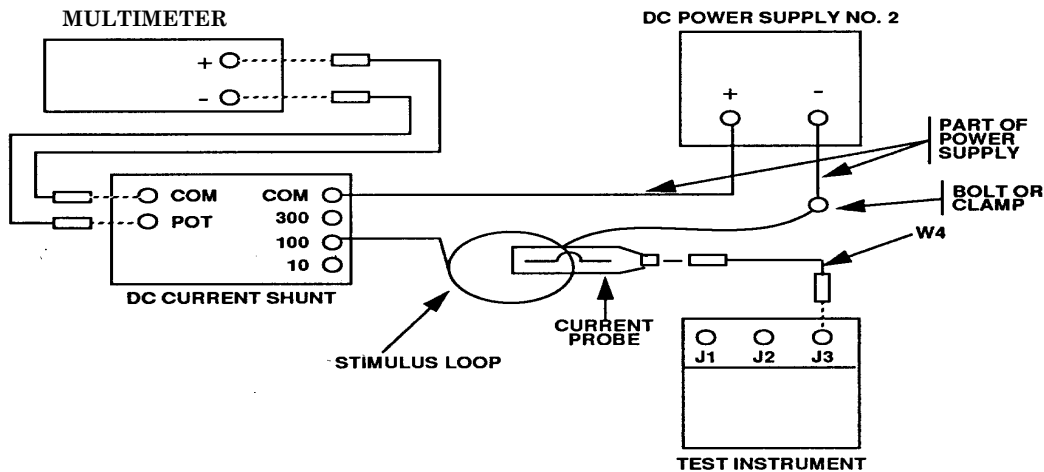

Figure 1. Dc current - equipment setup.

**NOTE**

Fabricate a current stimulus loop as shown in figure 1. The loop design should be 20 turns of No. 10 insulated copper wire with a bundle diameter of the turns being no more than 1 inch. The inside diameter of the loop should be 6 inches,  $\pm 1$  inch. Care should be taken to ensure that the loop does not overheat.

**NOTE**

Clamp current probe to stimulus loop with arrow on probe pointing in direction of current flow.

**CAUTION**

While performing this paragraph, minimize the time that current is running through the loop. High current will cause the wire to heat, thus increasing resistance and decreasing the loop current.

- (2) Set **TEST SELECT** switches to **90**.
- (3) Press and hold **TEST** pushbutton until **CAL** appears on TI display. Release **TEST** pushbutton.
- (4) Wait for offset values to appear on display. Offset values will be between **-225** and **+225**.
- (5) Place shorting plugs in 100 A position on dc current shunt.

(6) Adjust dc power supply No. 2 for a 25 mV indication on multimeter (25 A output).

(7) Press and release **TEST** pushbutton. If a – (negative) output occurs, reverse the current probe. If TI does not display between 435 and 565, perform **b** below.

**NOTE**

The current probe cannot be opened while the loop is energized due to the induced magnetic field.

(8) Repeat technique of (6) and (7) above for values and indications shown in table 4. If TI does not indicate within the limits specified, perform **b** below.

Table 4. Dc Current

Multimeter indications (mV)	Test instrument display	
	Min	Max
50	900	1100
55	990.8	1209.2
60	1081.2	1318.8
65	1171.2	1428.8
70	1260.8	1539.2
75	1350	1650

**b. Adjustments**

(1) Peel back decal on topside of probe to expose adjustment access hole.

(2) Adjust full-scale and span adjustments as necessary. Full-scale adjustment is closest to input connector end of current probe.

**11. Frequency**

**a. Performance Check**

(1) Connect function/arbitrary generator to TI J4 using cable W2.

(2) Adjust function/arbitrary generator for 500 Hz, and for a 6 to 10 V p-p square wave (**DC OFFSET** to **OFF**).

(3) Set **TEST SELECT** switches to **96**.

(4) Press and release **TEST** pushbutton.

(5) TI will indicate between 461.8 and 538.3 Hz.

**b. Adjustments.** No adjustments can be made.

## 12. RPM

### a. Performance Check

- (1) Connect function/arbitrary generator to TI J3 using cable W3 and W4.
- (2) Set **TEST SELECT** switches to **60**.
- (3) Press and release **TEST** pushbutton. Display will indicate **UEH**.
- (4) Set **TEST SELECT** switches to **01**.
- (5) Press and release **TEST** pushbutton. Display will indicate **1**.
- (6) Set **TEST SELECT** switches to **10**.
- (7) Press and release **TEST** pushbutton. Display will indicate **0**.
- (8) Adjust function/arbitrary generator for square wave (positive pulse) output of 7 to 13 V and 5000 RPM indication on TI display. Function/arbitrary generator will indicate between 165.84 and 167.50 Hz.
- (9) Repeat technique of (4) through (8) above for indications listed in table 5. Function/arbitrary generator will indicate within limits specified.

Table 5. RPM

Test instrument indications (RPM)	Function/arbitrary generator indications (Hz)	
	Min	Max
4500	149.16	150.83
4000	132.50	134.16
3500	115.83	117.49
3000	99.17	100.83
2500	82.50	84.16
2000	65.83	67.49
1500	49.16	50.83
1000	32.50	34.16
500	15.83	17.49
300	9.16	10.83
100	2.50	4.16
50	0.83	2.49

- b. Adjustments.** No adjustments can be made.

13. Pressure

**NOTE**

Operate hydraulic pressure standard in zero mode.

**a. Performance Check**

- (1) Connect equipment as shown in figure 2.

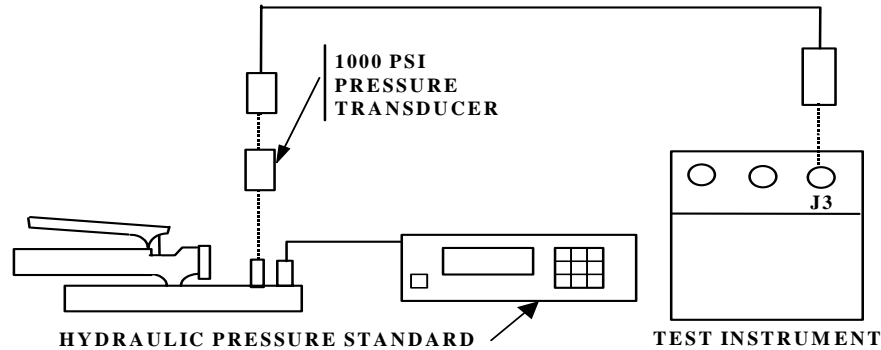

Figure 2. Pressure - equipment setup (1000 psi).

- (2) Set **TEST SELECT** switches to **50**.
- (3) Operate hydraulic pressure standard to apply 1000 psi and return to **0** three times.
- (4) With pressure at **0**, press and hold **TEST** pushbutton until **CAL** appears on TI display. Release **TEST** pushbutton.
- (5) Wait for offset value to appear on display. Offset value will be between **-150** and **+150**.
- (6) Press and release **TEST** pushbutton.
- (7) Operate hydraulic pressure standard to apply 300 psi. TI will indicate between 277.5 and 322.5.
- (8) Operate hydraulic pressure standard to apply 1000 psi. TI will indicate between 960 and 1040.
- (9) Connect equipment as shown in CONNECTION A (fig. 3).
- (10) Set **TEST SELECTOR** switches to **49**.

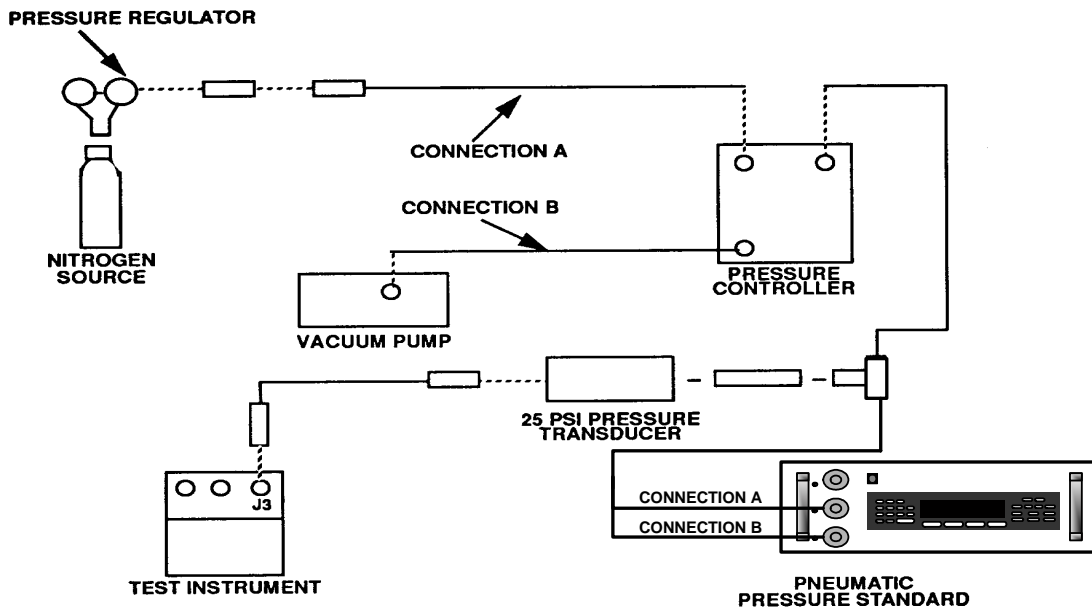

Figure 3. Pressure and vacuum - equipment setup (25 psi).

(11) Operate pneumatic pressure standard to apply 25 psi and reduce to **0** three times.

(12) With pressure at **0**, press and hold **TEST** pushbutton until **CAL** appears on display. Release **TEST** pushbutton.

(13) Wait for offset value to appear on display. Offset value will be between **-4** and **+4**.

(14) Press and release **TEST** pushbutton.

(15) Operate pneumatic pressure standard to apply 5 psi. TI will indicate between 4.5 and 5.5.

(16) Operate pneumatic pressure standard to apply 25 psi. TI will indicate between 24 and 26.

**b. Adjustments.** No adjustments can be made.

## 14. Vacuum

### a. Performance Check

- (1) Connect equipment as shown in CONNECTION B (fig. 3).
- (2) Set **TEST SELECT** switches to **45**.
- (3) Operate vacuum pump and adjust pressure controller and pneumatic pressure standard controls for 18 inHg indication and back to **0** three times.
- (4) Stop the vacuum pump and, with pneumatic pressure standard indicating **0**, press and hold **TEST** pushbutton until **CAL** appears on display. Release **TEST** pushbutton.
- (5) Wait for offset value to appear on display. Offset value will be between **-4.5** and **+4.5**.
- (6) Press and release **TEST** pushbutton.
- (7) Operate vacuum pump and adjust necessary controls for 18.00 inHg indication on pneumatic pressure standard. TI will display between 17.10 and 18.90.

**b. Adjustments.** No adjustments can be made.

## 15. Final Procedure

- a. Deenergize and disconnect all equipment and reinstall protective cover on TI.
- b. Annotate and affix DA label/form in accordance with TB 750-25.
- c. Label current probe, high-pressure transducer and low-pressure transducer with the following: "To be used only with VTM, Serial # \_\_\_\_\_ for VTM calibration to be valid".



**TB 9-4910-555-35**

By Order of the Secretary of the Army:

**ERIC K. SHINSEKI**  
*General, United States Army*  
*Chief of Staff*

**OFFICIAL:**

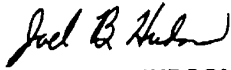

**JOEL B. HUDSON**  
*Administrative Assistant to the*  
*Secretary of the Army*

0314212

Distribution:

To be distributed in accordance with initial distribution number (IDN) 342040, requirement for calibration procedure TB 9-4910-555-35.



**Instructions for Submitting an Electronic 2028**

The following format must be used if submitting an electronic 2028. The subject line must be exactly the same and all fields must be included; however, only the following fields are mandatory: 1, 3, 4, 5, 6, 7, 8, 9, 10, 13, 15, 16, 17, and 27.

From: "Whomever" whomever@redstone.army.mil

To: <<mailto:2028@redstone.army.mil>>

Subject: DA Form 2028

1. **From:** Joe Smith
2. **Unit:** home
3. **Address:** 4300 Park
4. **City:** Hometown
5. **St:** MO
6. **Zip:** 77777
7. **Date Sent:** 19-OCT -93
8. **Pub no:** 55-2840-229-23
9. **Pub Title:** TM
10. **Publication Date:** 04-JUL-85
11. **Change Number:** 7
12. **Submitter Rank:** MSG
13. **Submitter FName:** Joe
14. **Submitter MName:** T
15. **Submitter LName:** Smith
16. **Submitter Phone:** 123-123-1234
17. **Problem:** 1
18. **Page:** 2
19. **Paragraph:** 3
20. **Line:** 4
21. **NSN:** 5
22. **Reference:** 6
23. **Figure:** 7
24. **Table:** 8
25. **Item:** 9
26. **Total:** 123
27. **Text**

This is the text for the problem below line 27.

**TB 9-4910-555-35**

**PIN: 052906-000**